

AP1016

VACUUMPUMP



www.aimspump.com

AP1016 SPECIFICATIONS

Rated Vacuum:	-35 kPa (-350mB, -10.34 inHg)
Rated Voltage(s):	100V, 120V or 230V
Maximum Vacuum Airflow:	>3.0 l/min (0.106 cfm)
Maximum Vacuum:	>-67kPa (-670mB, -19.78 inHg)
Rated Frequency:	50Hz or 60Hz
Power Consumption:	14-15 Watts
Duty Cycle:	Continuous
Coil insulation Class:	Class F. Class B for UL (1450) (120V)
Noise Level:	Below 40 dB (A)
Environmental Conditions:	0°C – 40°C & 35% - 85% RH
Mounting Dimensions:	48(L) x 62(W) mm
Unit outside dimensions:	99mm x 58mm x 58mm
Gross Weight:	700 grams (1.54lbs)
Lead Wire Length:*	AWG22 (UL1015, 105°C) X 260mm
Outlet:*	7.5mm diameter barb, hose nipple.

*Example given. Customer determined attributes are available.
Patented and patents pending

Typical exhaust characteristics
10.5L volume

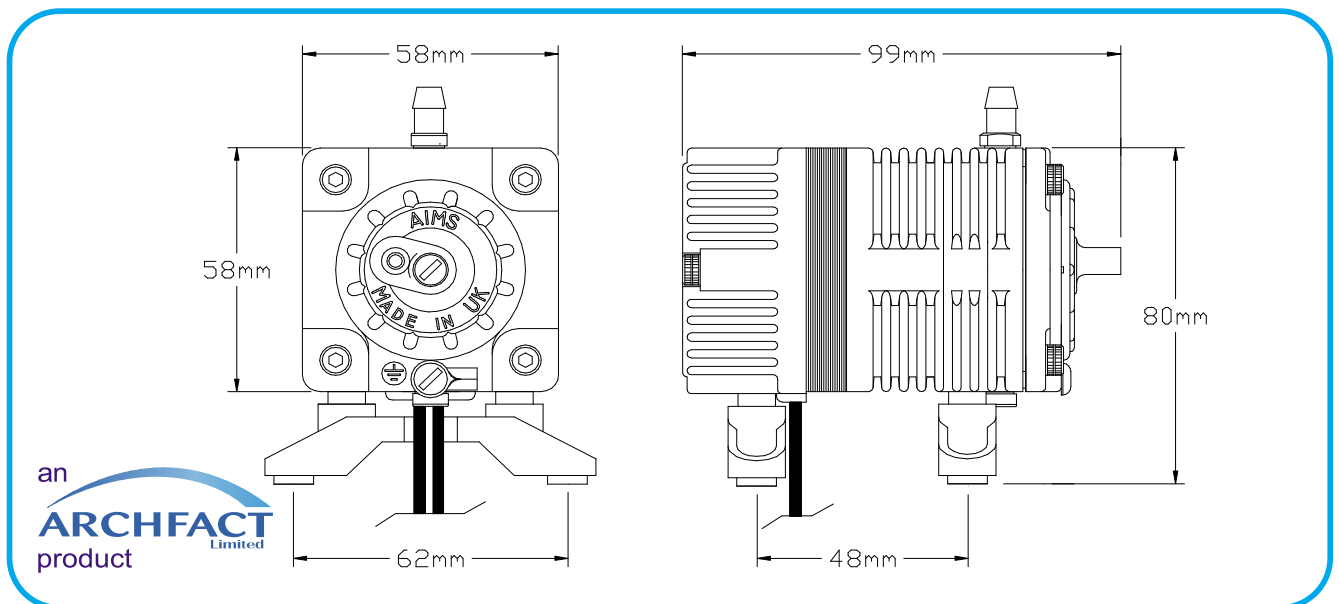
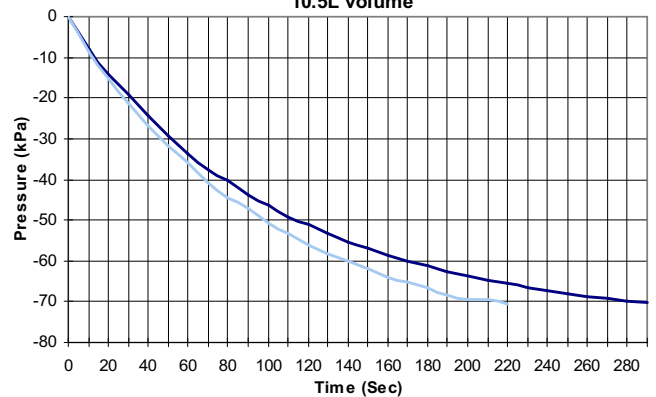

an
ARCHFACT
product
Limited

Contact technical sales for additional information regarding life expectancy and operating conditions.
All the information in this datasheet is supplied in good faith.
This information is given without obligation or liability.